

Mechanical Reasoning – Practice Test 1

Explanatory Notes

Mechanical reasoning tests measure your knowledge of straightforward mechanical and physical concepts. They do not measure your underlying mechanical aptitude in the same way that abstract reasoning questions measure your underlying intellectual ability. For example, you could sit an abstract reasoning test without having seen one before and still get a reasonable score. The same is not true of mechanical reasoning where your score will depend significantly on your knowledge of:

- Levers
- Pulleys
- Gears
- Springs
- Simple Electrical Circuits
- Tools
- Shop Arithmetic

You may have come across: levers, pulleys, gears, springs and simple circuits in elementary science and the questions on these topics are fairly straightforward. If elementary science classes seem like a long time ago and you need to refresh your memory then read ‘Mechanical Reasoning Tests – What You Need to Know’ before you attempt these practice tests.

If you are taking a test as part of the selection for a craft or apprenticeship job, then you may be asked some questions about tools and how they are used. These questions are again straightforward and if you have spent significant time fixing or making things, they won’t present any problems. However, mechanical goods of all types are relatively cheaper, less prone to breakdown and often less repairable than they were 20 years ago. This means that many people under 30 years of age don’t have much practical experience of fixing things or of watching someone else do so. If you feel that this applies to you, then you will need to make some effort to improve your knowledge of everyday tools. You can do this by getting hold of a catalog for a tool hire company and simply reading through it – boring but effective.

If you are taking a test as part of the selection for a craft or apprenticeship job you should also expect some shop arithmetic questions. These questions approximate the type of reasoning and maths that are needed to estimate materials costs etc. You will need to know the formulae for calculating the areas and volumes of simple shapes, as well as familiarity with imperial units including: inches, feet and yards. For example, you need to know that there are nine square feet in a square yard, something which surprises many people brought up using only metric units! These are again dealt with in ‘Mechanical Reasoning Tests – What You Need to Know’.

One final point, many of the questions in mechanical reasoning tests are ‘industry’ specific. For example, tests used by the fire service tend to frame the questions in terms of fire-fighting whereas tests used to select for an aircraft maintenance job would tend to frame the questions in aviation industry terms. It doesn’t matter if the questions you practice on aren’t specific to the industry you are applying for. It is the substance of the question that is important – the scenario is incidental.

Mechanical Reasoning – Practice Test 1

Test 1: 20 Questions

Answer as many questions as you can in 15 minutes. Circle the letter below the question which corresponds to the correct answer. You are advised to use a calculator.

1) How much weight is required to balance the lever?

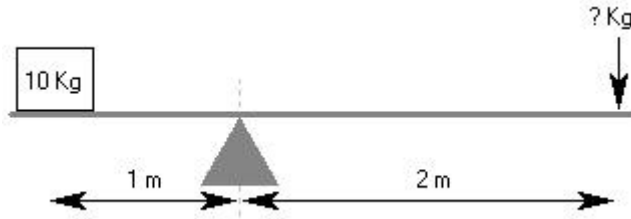

A	B	C	D	E
15Kg	5Kg	10Kg	7.5Kg	20Kg

A B C D E

2) How far from the fulcrum does the 60 lb weight need to be to balance the lever?

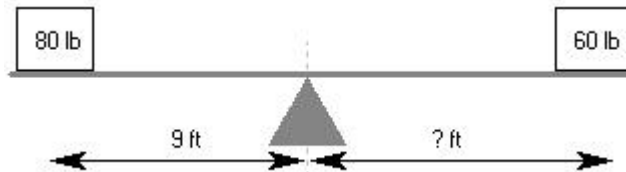

A	B	C	D	E
9 ft	7 ft	14 ft	12 ft	10 ft

A B C D E

3) How much weight is required to balance the lever?

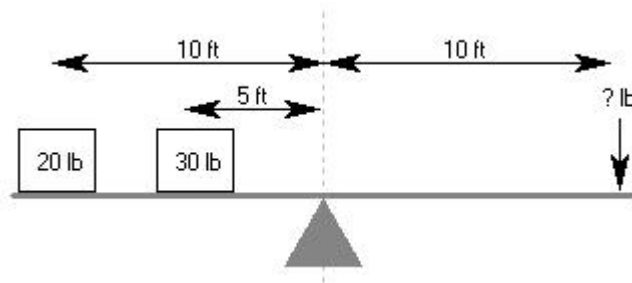

A	B	C	D	E
30 lbs	25 lbs	28 lbs	40 lbs	35 lbs

A B C D E

Mechanical Reasoning – Practice Test 1

4) Approximately how much force is needed to lift the weight?

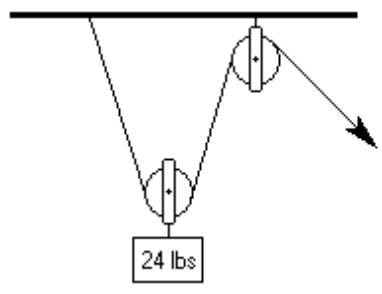

A	B	C	D	E
24 lbs	10 lbs	48 lbs	12 lbs	18 lbs

A B C D E

5) Approximately how much force is needed to lift the weight?

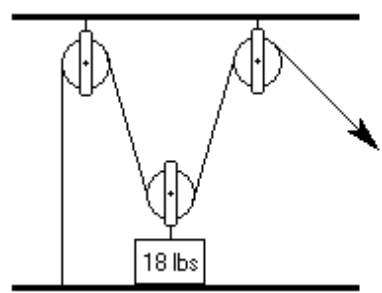

A	B	C	D	E
36 lbs	10 lbs	18 lbs	9 lbs	14 lbs

A B C D E

6) If gear X turns clockwise at a constant speed of 10 rpm. How does gear Y turn?



A	B	C	D	E
anti c/w 10 rpm	c/w 10 rpm	c/w 5 rpm	anti c/w 5 rpm	c/w 20 rpm

A B C D E

Mechanical Reasoning – Practice Test 1

7) If gear X turns clockwise at a constant speed of 10 rpm. How does gear Y turn?



A	B	C	D	E
anti c/w 10 rpm	c/w 10 rpm	c/w 5 rpm	anti c/w 5 rpm	c/w 20 rpm

A B C D E

8) If bar Y moves left a constant speed. How does bar X move?

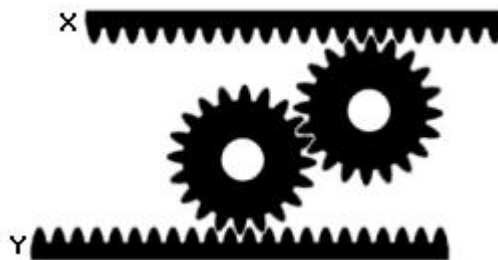

A	B	C	D	E
Left, Faster	Left, Same	Left, Slower	Right, Same	Right, Slower

A B C D E

9) If drive wheel X rotates clockwise at a speed of 10 rpm. How does wheel Y turn?

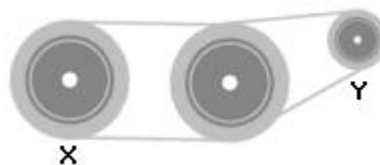

A	B	C	D	E
anti c/w faster	c/w slower	c/w faster	anti c/w slower	anti c/w same

A B C D E

Mechanical Reasoning – Practice Test 1

- 10) If drive wheel X rotates clockwise at a speed of 10 rpm. How does wheel Y turn?

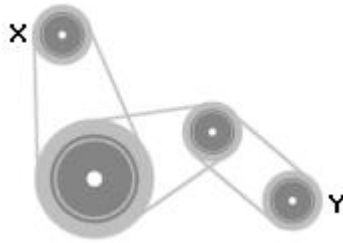

A	B	C	D	E
anti c/w faster	c/w slower	c/w faster	anti c/w slower	c/w same

A B C D E

- 11) A force of 5 Kg compresses the springs in series 10cm. What will be the total distance that the springs in parallel are compressed?

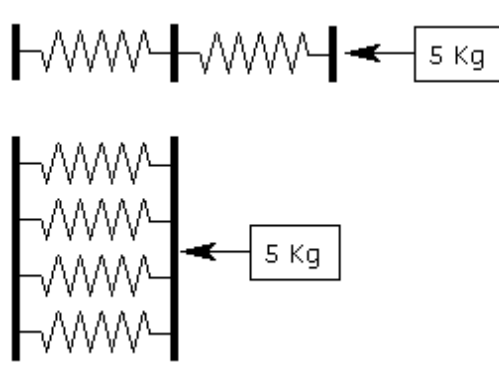

A	B	C	D	E
2.5 cms	5 cms	7.5 cms	10 cms	15 cms

A B C D E

Mechanical Reasoning – Practice Test 1

12) In the circuit shown, how many switches need to be closed to light up one bulb?

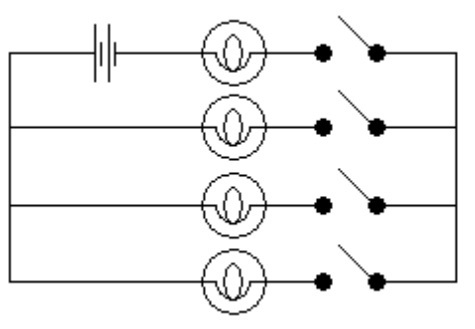

A	B	C	D	E
None	One	Two	Three	Four

A B C D E



13) Which is the most suitable tool for breaking up concrete?

A	B	C	D	E
None	1	2	3	4

A B C D E

14) Which is the most suitable tool for assembling a friction fit wooden frame?

A	B	C	D	E
None	1	2	3	4

A B C D E

Mechanical Reasoning – Practice Test 1



15) Which tool or combination of tools would be most useful for general woodworking?

A	B	C	D	E
4 & 2	3, 5 & 7	2, 4 & 6	4 & 7	3 & 6

A B C D E

16) Which tool or combination of tools would be most useful for repairing a broken radio?

A	B	C	D	E
1 & 8	3, 5 & 7	8	1 & 9	3 & 6

A B C D E

Mechanical Reasoning – Practice Test 1

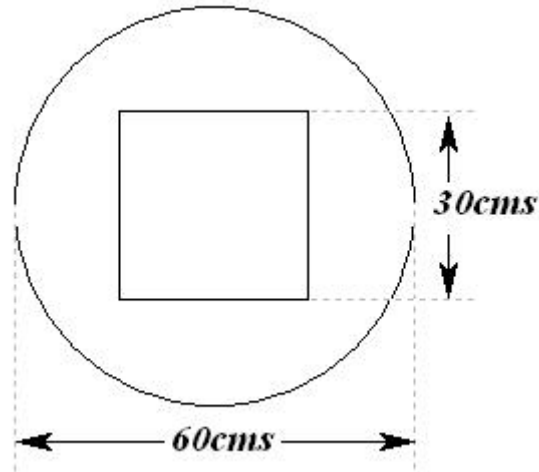

The sketch above shows a component which is stamped out of sheet steel. The square in the center is discarded. These components are stamped out of a continuous steel coil with a width of 70 cms. The stamping process requires a gap of 25mm between each component. The steel coil is supplied in lengths of 25 meters costing \$200.

- 17) What is the approximate area of the remaining shape in square centimetres?

A	B	C	D	E
1938	1855	1926	1880	1760

A B C D E

- 18) What is the approximate percentage of steel wasted including the center square?

A	B	C	D	E
56%	50%	62%	48%	52%

A B C D E

- 19) Assuming minimal wastage, how many components can be produced from each 25 meter coil?

A	B	C	D	E
38	40	36	42	37

A B C D E

- 20) What is the approximate cost of a component if the scrap is sold at 50% of cost?

A	B	C	D	E
\$3.60	\$3.15	\$3.55	\$5.00	\$4.85

A B C D E

End of Mechanical Reasoning - Test 1

Mechanical Reasoning – Practice Test 1

Products to Help You Succeed in Psychometric Tests

Anyone that has tried to secure a job in today's market knows that a dazzling CV and a compelling interview are simply not enough. Candidates are now faced with a rigorous assessment of their abilities and their personality in the form of a psychometric test.

Maximise your performance in under 2 weeks!

Psychometric tests are now an integral part of the recruitment process, especially when it comes to finding candidates for those coveted top jobs. So, it's hardly surprising that seemingly well-qualified candidates are being overlooked in favour of applicants that excel at psychometric tests.

So, if you want to get that all important first job, or if you are hoping to further your career, now is the time to take positive action to increase your chances of success.

Topic Level eBooks



These eBooks teach you how to master specific aspects of psychometric analysis, such as numerical, verbal, abstract, spatial, mechanical reasoning and personality tests. Pass your psychometric tests with flying colours! These downloadable eBooks provide immediate access to expert know-how and essential insight that will give you the edge over the competition. Visit www.psychometric-success.com

Job Level eBooks



These eBooks give you the opportunity to work through complete sets of practice questions that are used to assess candidates for specific types of work, such as management, graduate, technical, supervisory and clerical level jobs. Each one of these books is a complete solution and contains everything you need to succeed in psychometric tests no matter what level of job you are applying for. Visit www.psychometric-success.com

Mechanical Reasoning – Practice Test 1

Answers to Mechanical Reasoning Test 1

Question	Test 1
1)	B
2)	D
3)	E
4)	D
5)	D
6)	B
7)	D
8)	B
9)	C
10)	E
11)	A
12)	C
13)	D
14)	C
15)	B
16)	D
17)	C
18)	A
19)	B
20)	C